



Co-funded by  
the European Union



Result to WP/ Activity:

## 3.4 Creation of OER repository and lesson plans

Leading organization: University of Jyväskylä

Partner organization:

University of Ostrava

University of Luxembourg

Johannes Kepler University Linz

Comenius University Bratislava





Co-funded by  
the European Union



Project: Accelerating STEAM-related  
Knowledge and Skills via 3D Modelling and 3D  
Printing  
Reg. no. 2023-1-CZ01-KA220-HED-000160664

## Teaching Planning Tool – 3D Modelling and 3D Printing (STEAM)

Template (2 parts: Conceptual Planning + Lesson Plan). Replace the square brackets with your own content. 3D printing and modelling as a tool for the creative development of students' knowledge and skills (original designs, iterations)

### PART 1: Conceptual Planning (General Information)

#### Title of the Thematic (STEAM) Unit

STEAM primary science education in the preparation of future teachers, elementary pedagogy students

**Authors (Names / School / Country):** Mgr. Mária Fuchsová, PhD. (Department of Mathematics and Science Education, Faculty of Education, Comenius University, Bratislava)

SUBJECT	Natural Science Practice – living nature
YEAR	1st and 2nd year of the Master's degree program in Teaching for Primary Education
NUMBER OF LESSONS	3 lessons (Lesson 1: motivation, discussion of the topic, division of tasks in the project, Lesson 2: examples of work in the Tinkercad, PrusaSlicer programs, explanation of STEAM education, 3D modelling and printing, Lesson 3: project evaluation, discussion between groups - project evaluation and discussion took place after the students had worked on the project for a month, the students consulted the teacher on the individual steps of the project continuously in the subject of Natural Science Practice)
DIDACTIC OBJECTIVES	In the Natural Science Practice class for the area of living nature, students of the Primary Education study program at the Faculty of Education, Comenius University in Bratislava worked on a project to design and 3D model a STEAM aid for determining animal species according to typical tracks, usable in primary science education.
SPECIFIC OBJECTIVES	Cognitive objectives: As part of the project, students learn how animals move in a given environment, what traces they leave when moving, and how these traces can be recognized without directly seeing the animal in nature. At the same time, they evaluated which animal is the most typical for the assigned group of animals (mammals, birds, reptiles, amphibians) or is closest to the environment of a primary school student. When designing a STEAM aid, they learn to think interdisciplinary (using new technologies, art, mathematics, and engineering in science education). Affective objectives: Students work on a project to design and model a STEAM aid in a group. Within the group, they learn to respect the opinions of their classmates,



Co-funded by  
the European Union



Project: Accelerating STEAM-related  
Knowledge and Skills via 3D Modelling and 3D  
Printing  
Reg. no. 2023-1-CZ01-KA220-HED-000160664

	<p>discuss the problem, and accept solutions that they have jointly evaluated as the most successful for solving the problem.</p> <p>Psychomotor objectives: When designing and modelling a STEAM aid, students strengthen their digital skills (working in Tinkercad and PrusaSlicer), develop their creativity and motor skills when designing prototypes of a STEAM aid using various techniques and materials.</p>
--	--

## THEMATISATION AND PROBLEMATISATION

*Why is the topic meaningful, and what problem does it address?*

*Key questions and didactic strategy (e.g. PBL, constructionism, EUR method).*

The topic of identifying animals in nature without their direct presence is highly topical. In the last 10 years, the number of direct human contacts with wild animals (mainly with brown bears or wild boars) has been increasing in Slovakia, not only in the forest environment, but also in the city or village environment. By educating pupils and students to recognize animal tracks, we can reduce the number of such unwanted encounters and prevent injuries or even deaths. In the project, we are therefore addressing the key question of how animal tracks in nature can be recognized and whether we could create a simple aid with which we could recognize animal tracks directly in the field. To solve the problem, we have chosen the didactic strategy of project and problem-based teaching. Problem-based teaching due to solving a real problem from the lives of pupils (students) and project teaching due to creating a STEAM aid as a key to identifying animal species directly in the field. In the Natural Science Practice class (area of living nature), we work with primary education teacher students, so we thematically oriented the project to a topic with content focused on primary natural science STEAM education, so students will be able to use the created aid in their future pedagogical practice. The new curriculum for the educational area "Man and Nature" (ŠVP, 2023) is up to date in terms of applying STEAM principles, but it depends on the teacher's experience to be able to apply these principles to education. Therefore, we consider it essential to prepare future teachers for pedagogical practice.

## STUDENTS' ENTRY SKILLS

- Basics of TinkerCAD
- Experience with GeoGebra3D
- Working with STL/OBJ files
- Basic slicing (PrusaSlicer / Cura / Bambu Studio)
- Experience with other software (please specify): ...
- 3D printing safety

## 3D AIDS AND SOFTWARE

- Modelling software: TinkerCAD





Co-funded by  
the European Union



Project: Accelerating STEAM-related  
Knowledge and Skills via 3D Modelling and 3D  
Printing  
Reg. no. 2023-1-CZ01-KA220-HED-000160664

- Slicer: PrusaSlicer
- Viewer/AR:

### 3D PRINTING

Equipment required for the activity: Original Prusa i3 MK3S

### Learning objectives related to 3D modelling and printing

Main objective:

3D modelling and printing (3DMP) is a aid for developing spatial imagination. Students must think about how, using geometric shapes or the drawing function, they will design a prototype of a STEAM aid, created using various techniques and materials, into the virtual space of the Tinkercad program. At the same time, the STEAM aid model must be designed in such a way that it can be printed using a 3D printer.

Secondary objectives:

Students will learn to perceive 3D printing technology as an environmental solution. They will learn about the possibilities of recycling PLA material, or the design of a aid that is not single purpose but can be used repeatedly in teaching.

### STEAM Elements

STEAM ELEMENT	CHARACTERISTICS OF THE ELEMENT IN THE ACTIVITY
SCIENCE	Step 1: In the group, the students discussed which animal could be a typical representative of the given group (mammals, birds, reptiles and amphibians) suitable for learning in primary science education. At the same time, they had to consider the fact that the given animal also moves on land, and it is likely that we will record its typical footprint in nature (they considered the environment in which the animal lives). After choosing a suitable animal, they observed how it moves in the given environment, what shape and size is its limb, which leaves a footprint in nature when moving on a suitable surface (clay, mud, snow, wet footprint on the sidewalk, etc.).
TECHNOLOGY	Step 5: The final prototype of the aid within the group was modelled in the Tinkercad program. The students decided to either select for 3D modelling the aid prototype that met all the criteria (a aid suitable for STEAM education, as well as the ability to model it using geometric shapes and the drawing function in the Tinkercad program) or create a new design within the group, in which they took into account elements from several aid prototypes within the group. The results of the project were presented in PowerPoint to all groups in the Natural Science Practicum class. After mutual discussion, the students selected one aid, which they printed using a 3D printer.



Co-funded by  
the European Union



Project: Accelerating STEAM-related  
Knowledge and Skills via 3D Modelling and 3D  
Printing

Reg. no. 2023-1-CZ01-KA220-HED-000160664

ENGINEERING	Step 3: Students created prototypes of the STEAM aid to visualize their designs and to be able to present to each other why their prototype aid would be suitable for primary science STEAM education. Some students used drawings (sketches) of the prototype aid, some students modelled the prototype from simple available materials.
ARTS	Step 2: After studying the way a given animal moves and the typical track it leaves, the students created designs for a STEAM aid that would help us identify the selected representative directly in the field and which could also be used in primary science STEAM education.
MATHEMATICS	Step 4: Within the group, the students discussed which of the submitted prototypes of the aid would be useful not only for STEAM education, but they would also be able to model the aid in the Tinkercad program (3D modelling) using basic geometric shapes (sphere, hemisphere, cylinder, cube, pyramid, rectangle, etc.) and the drawing function.

### Syllabus of Cross-Curricular Links

SUBJECTS	AREA OF LEARNING	CONTENT STANDARD	PERFORMANCE STANDARD
Human and Nature	Human and Nature (Evolution content component, 2nd cycle of primary education)	Organisms adapt in various ways to the environment in which they live.	Making and comparing prints and casts of organisms and their tracks.
Mathematics	Mathematics and Computer Science (Geometry content component, 2nd cycle of primary education)	Simple planar geometric shapes, properties and relationships. Simple spatial geometric shapes, properties and relationships.	Mathematical modelling.
Informatics	Mathematics and Informatics (Technology content component, 2nd cycle of primary education)	Hardware and software	Using various application software (e.g. school educational software, digital textbook, encyclopaedia) that is age appropriate.
Human and the World of Work	Human and the World of Work (Technology content component, 2nd cycle of primary education)	Investigating technical materials and their properties.	Construct a simple object, present and defend the results of your work in the field of simple construction and



Co-funded by  
the European Union



Project: Accelerating STEAM-related  
Knowledge and Skills via 3D Modelling and 3D  
Printing  
Reg. no. 2023-1-CZ01-KA220-HED-000160664

			design in front of a group.
Art Education	Art and Culture (content component Communication, 2nd cycle of primary education)	Techniques of drawing, painting, graphics, modelling, spatial creation and their combinations.	Purposefully use aids, materials, techniques, technologies.

## PART 2: Specific Planning – Lesson Plan

**Title of the Lesson:** Project of design and 3D modelling of STEAM aid for identifying animal species based on typical tracks

### Lesson Objectives:

Cognitive objectives:

As part of the project, students learn how animals move in a given environment, what traces they leave when moving, and how these traces can be recognized without directly seeing the animal in nature. At the same time, they evaluated which animal is the most typical for the assigned group of animals (mammals, birds, reptiles, amphibians) or is closest to the environment of a primary school student. When designing a STEAM aid, they learn to think interdisciplinary (using new technologies, art, mathematics, and engineering in science education).

Affective objectives:

Students work on a project to design and model a STEAM aid in a group. Within the group, they learn to respect the opinions of their classmates, discuss the problem, and accept solutions that they have jointly evaluated as the most successful for solving the problem.

Psychomotor objectives:

When designing and modelling a STEAM aid, students strengthen their digital skills (working in Tinkercad and PrusaSlicer), develop their creativity and motor skills when designing prototypes of a STEAM aid using various techniques and materials.

**Expected Student Outcomes:** [List of specific outcomes]

- Project presentations in PowerPoint
- 3D STEAM aids suitable for identifying animals in nature usable in primary science education

### Lesson Plan (Phased Description)

*Typical phases: Introduction – motivation, objectives, criteria. Student Learning – knowledge processing, planning. 3D Modelling – CAD work. 3D Printing – slicing and printing.*





Co-funded by  
the European Union



Project: Accelerating STEAM-related  
Knowledge and Skills via 3D Modelling and 3D  
Printing  
Reg. no. 2023-1-CZ01-KA220-HED-000160664

## 1. Lesson – motivation, presentation of the problem and discussion, division of tasks in the project.

### *Motivation:*

We know that animals can live in different environments – on land, rocks, caves, in soil, in air, in water, on other animals, in human dwellings (Dobišová Adame and Kováčiková, 2015). They are part of various natural communities where they live together with other organisms, e.g. the community of forests, meadows, fields, aquatic community. Animals have also adapted to this environment with their body shape and way of life. Question for discussion: Can you give an example of how different animals are adapted to the given environment that we have just listed? (e.g. carp swims in water, therefore it has gills, scales on the surface of the body and its limbs have been transformed into fins, therefore the movement of animals is also adapted to the environment in which they live, while animals use various parts of the body such as wings, fins, limbs for movement).

Because animals often live in hiding, are shy or active only at night, their tracks are the most important and often the only evidence of their presence (Richarz, 2009). Question for discussion: “By what tracks would you be able to recognize an animal in nature without actually seeing it” (e.g. even when animals are hiding, they leave behind many tracks, such as prints, structures or food remains). We can indeed get to know animals in nature indirectly, when we do not see the animal itself in nature. However, we must be well acquainted with their way of life and the way they move in a given environment. By recognizing an animal's track, we can prevent an unwanted encounter with dangerous wild animals and prevent our injury or even death. Currently, this topic is very relevant in Slovak society, because we often come across information that a person was injured in contact with a brown bear. Let's try to become good trackers so that we can avoid a similar encounter with a dangerous animal.

### *Approaching the issue, learning about the problem:*

Animal tracks are visible in various places. Many animals often move along the same route and often stay at the edge of the forest. Many tracks are also found in places where the animal regularly eats, e.g. you can often find a handful of nuts gnawed by a squirrel, a lot of owl droppings in a barn, pinecones dug out by a woodpecker near tree stumps or pieces of tree bark peeled by a beaver (Lisak, 2004).

Animal tracks that we can recognize in nature can be of various types (Swojtka & co., 2014):

- movement – footprints, broken bushes when crossing,
- bed tracks – left in beds, in dens, sleeping places, in nests,
- gnawing – gnawed trees (e.g. typical “pencils” from beavers), peeled bark,
- excretory – droppings and excrement,
- vocal – many sound expressions of mammals and birds,
- various others – fur caught on trees, shed antlers, lost feathers.

On a suitable surface, a limb leaves a trace as a positive imprint (Richarz, 2009). Tracks in such a surface can be left mainly by groups of amphibians, reptiles, birds and mammals that live at least part of their lives on



Co-funded by  
the European Union



Project: Accelerating STEAM-related  
Knowledge and Skills via 3D Modelling and 3D  
Printing  
Reg. no. 2023-1-CZ01-KA220-HED-000160664

land. Fish live in water, so you can't find their footprints on land. Invertebrates, on the other hand, either don't have any, or if they do, their footprints are barely visible on land. The shape, size, and placement of their footprints can give you an idea of how different animals move in a given environment (Townsend, 2018).

Mammals are divided into flatfooted animals, fingerlings, and ungulates based on their limb structure. While flatfooted animals tread on the entire surface of their feet and walk slowly (e.g. badgers), fingerlings leave only their toes (the pads of their toes) or their last joints and the pad of their feet, which allows them to run faster (e.g. foxes). The thumb may not always be left on the ground in mammals (especially fingerlings) (Richarz, 2009; Svojtka & co., 2014; Lisak, 2004).

In ungulates, the end of the limb is protected by a horny structure, the hoof, so they step on the tips of the last digit segments (e.g. chamois, roe deer). Ungulates are divided into artiodactyls and odd-toed ungulates. The hooves of artiodactyls are called hooves. Ungulates have 4 toes, but only the middle two usually create an imprint. For example, a wild boar leaves 4 toes, the two rear prints are the traces of the hooves, the two front, larger prints are the prints of the two middle toes (hooves). The tracks of artiodactyls are often similar, usually differing only in the length and thickness of the print, or the length of the belly in the hoof (deer, fallow deer, roe deer, chamois, sheep, etc.). The tracks are clearly visible in sand and on muddy paths, after rain, or also on the banks of ponds and rivers. Tracks are best read in the snow, especially when it falls at night and they are clearly visible in the morning. In even-toed ungulates, the horny sheath at the end of the toes is called a hoof (e.g. horse and donkey) (Richarz, 2009; Svojtka & co., 2014; Lisak, 2004; Hecker, 2019).

Despite the fact that mainly small birds rarely stay on the ground, you can find a lot of their tracks on a suitable surface. These can help determine not only their species, but also in evaluating the activity of birds. When looking for bird tracks, you can successfully use damp banks and sandy or muddy areas. The shape of the bird's footprint is closely related to the structure of the foot. There are usually four toes arranged around the lower part of the foot. The often stunted first toe points backwards, the second (inner) to the side of the body, the third (middle) is usually the longest. The fourth (outer) toe points inwards. The lower part of the running foot, the pads of the toes and the claws leave prints. According to the main function, different types of feet are distinguished in birds: grasping, walking, rowing, swimming (Richarz, 2009). Water birds usually have the front three toes connected by a web (e.g. duck) or have a rim around the toes (e.g. coot) (Svojtka & co., 2014).

We divide reptiles into several groups, of which only members of the turtles, annelids and pangolins live in nature in Europe (this includes legless snakes and lizards, most of which have legs). The similarity of the tracks of different species means that they are not of great importance for identification. Similarly, other signs, such as hatched eggs, are interesting but not easily recognizable. On the other hand, the shed skin is of great importance in the attempt to identify lizards and snakes, because it preserves the characteristic structure of the scales and patterns, even traces of colour. Lizard tracks are often seen in sandy areas, but they can rarely be attributed to a specific species, they are footprints and tail marks (Gibson, 2005).

The legs of amphibians have adapted to their lifestyle, for example, some have gripping plates on their toes, others have swimming membranes between their toes. In our conditions, salamanders and frogs live and are distinguished by whether they have a tail in adulthood. Amphibians leave few recognizable tracks



Co-funded by  
the European Union



Project: Accelerating STEAM-related  
Knowledge and Skills via 3D Modelling and 3D  
Printing  
Reg. no. 2023-1-CZ01-KA220-HED-000160664

behind. Apart from hearing their voices or finding them in their early stages of development, the only possible way to record their presence is to find an adult individual (Gibson, 2005).

When determining the age of a track, various circumstances must be taken into account. Weather is crucial — wind, air humidity, rain, and temperature all influence how quickly a track weathers and eventually disappears. The quality of the ground also plays a role: footprints in muddy soil remain preserved longer than those in sand or in raw humus made of coniferous and deciduous leaves, which dries out very quickly in the wind and causes footprints to crumble (Svojtka & Co., 2014).

An animal can also deceive with its tracks. Do you know how? If an animal places its feet into the footprints of another animal, it leaves no tracks of its own. Wolf packs do this, for example, making it very difficult to determine the number of individuals based on their tracks. Some animals, such as deer, can walk several meters back in their own trail and then suddenly change direction. This creates a dead end that can confuse a potential pursuer (Svojtka & Co., 2014).

#### *Project objective and implementation:*

After presenting the problem, we encouraged students to design and create an aid that could help us recognize animal tracks directly in nature (in the field) and at the same time be usable in primary science STEAM education. We divided the students into groups, with each group designing and modelling a STEAM aid for determining different representatives of animals (the group that designed an aid for determining the species of mammals, birds, reptiles and amphibians, if we have more students, the mammal groups can be divided into flatworms, pinnipeds and ungulates - therefore, we can divide the students into 4 or 6 groups). Each group had to design a typical representative of the given group for the aid and justify their choice. The students worked on the prototype of the aid and modelling in the Tinkercad environment for a month. Over the course of the month, the assignments were continuously consulted with the teacher in the Science Practicum class, as well as among individual members of the student group.

## 2. Lesson - examples of work in Tinkercad, PrusaSlicer, explanation of STEAM education and 3D modelling and printing

#### *Motivation:*

3D printing is a widely used technology in many STEAM areas and is often integrated into education in order to engage students or pupils in active learning. The use of active learning strategies has been shown to improve learning, as well as school performance and reduce failure rates (Guenther et al., 2021). STEAM is an educational curriculum based on education in five basic areas - science, technology, engineering, art and mathematics. It differs from other curricula in that it strives to teach the aforementioned basic areas as a whole, i.e. it focuses on integrated learning. STEAM is an increasingly popular way of education in which the student, or pupil, becomes a creator of knowledge, not just a reproducible source of information, through an interdisciplinary approach to learning.





Co-funded by  
the European Union



Project: Accelerating STEAM-related  
Knowledge and Skills via 3D Modelling and 3D  
Printing  
Reg. no. 2023-1-CZ01-KA220-HED-000160664

3D printing in science education can be used in various ways, for example, in creating 3D models of human anatomy and cell microstructures to improve three-dimensional understanding of anatomical structures and understanding of complex physiological relationships, in environmental education, where filaments for 3D printing can be used from waste plastic material, or in creating 3D models that serve as tactile aids for visually impaired students (Hansen et al., 2020). In the Science Practicum class, students will learn how to use a 3D printer to create an aid that will help them identify animal tracks directly in nature and that would also be reusable in primary science STEAM education. At the same time, we will remind students that the PLA filaments for 3D printing themselves are made from corn starch or sugar cane, therefore they are recyclable and suitable for creating another aid.

*Approaching the issue, learning about the problem:*

We used one lesson to introduce 3D modelling and 3D printing programs so that students, when creating a aid, had an idea of how to design the aid so that they could actually print it using a 3D printer. First of all, students had to log in to the freely available Tinkercad program through personal accounts. In the process of 3D modelling (creating a new 3D object), we introduced the students to the virtual environment of the program, the basic orientation of the object in space, the method of using basic geometric shapes, the free drawing function, as well as the possibility of combining and dividing objects in space. Then, we introduced the students to how to import a 3D object into a STL file and transfer it to the pre-installed PrusaSlicer program. In this program, students learned how to modify a 3D object into a form suitable for 3D printing on a specific 3D printer (Original Prusa i3 MK3S 0.25 nozzle). These included functions for modifying the internal structure, surface treatment, or the size of the 3D model and its correct orientation suitable for 3D printing. In the PrusaSlicer program, students learned how to generate a G-code with which they can print the 3D object. It was important to remind students of the safety of working with 3D printing, because the printer operates in high temperature conditions (up to 220°C). All functions in the Tinkercad and PrusaSlicer programs were available for all students to try out on their personal laptops during the class.

The task for 3D modelling and 3D printing was subsequently specified for the STEAM use of the aid:

S – using the aid, it will be possible to recognize animals in nature

T – activity proposal, where the aid will be used in the task of developing students' digital literacy

E – activity proposal, where the aid will be used in the task of developing students' technical literacy, students will use the aid to construct, assemble, connect, manipulate

A – activity proposal, where the aid will be used in the task of developing students' artistic literacy

M – activity proposal, where the aid will be used in the task of developing students' mathematical literacy

3. Lesson: project evaluation, discussion between groups – project evaluation and discussion took place after a month of students' work on the project, students continuously consulted the individual steps of the project with the teacher during the subject of Natural Science Practice, students presented their results in PowerPoint



Co-funded by  
the European Union



Project: Accelerating STEAM-related  
Knowledge and Skills via 3D Modelling and 3D  
Printing  
Reg. no. 2023-1-CZ01-KA220-HED-000160664

Students presented the results of their projects in a group and discussed the results with each other. Here are a summary and evaluation of the results:

### Choosing an animal

Students chose a typical representative of the given group according to various criteria. One of the most common criteria was the environment in which the animal lives. As a suitable environment and animal that moves in it, they suggested one that is close to a child of younger school age, i.e. the environment around the school or his/her residence. Another criterion was their own experience with the popularity of a given animal among children of a given age, e.g. an animal is often presented as the main character of fairy tales, poems and fables. The motivation for choosing a typical representative was, in addition to the preference of the animal by children, also the elimination of misconceptions or emphasising its importance for humans. An important note in choosing a typical representative was compliance with the content and performance standards of the current SVP for primary science education.

For the group of mammals – plantigrades, the students chose the dark hedgehog, for the group of mammals – digitigrades the domestic cat, for the group of mammals – ungulates the forest roe deer, for the group of birds the domestic pigeon, for the group of reptiles the wall lizard and for the group of amphibians the common toad.

### Design of a 3D aid prototype

After discussion and selection of a suitable typical representative of a given group of animals, the students presented initial prototypes of a 3D aid for identifying animals using footprints, which would also be useful in primary science STEAM education. The students designed the initial prototypes of the aids using various techniques and using various materials. They either drew the prototype of the aid or modelled it from various materials such as plaster, plasticine, modelling clay, paper, wire, twine, sponge. The designs of some prototypes are shown in Figures 1 and 2. In the group, the students thought about prototype designs that would meet all the conditions for STEAM education or evaluated which of the prototypes could be modelled and printed in PrusaSlicer using geometric shapes and the drawing function in the Tinkercad program. After mutual discussion, the students either selected a suitable prototype for 3D modelling or created a new design that considered elements from multiple prototypes of the aid within the group.



Figure 1. Prototypes of STEAM aids for determining mammal species (digitigrades, plantigrades and ungulates)



Co-funded by  
the European Union



Project: Accelerating STEAM-related  
Knowledge and Skills via 3D Modelling and 3D  
Printing  
Reg. no. 2023-1-CZ01-KA220-HED-000160664

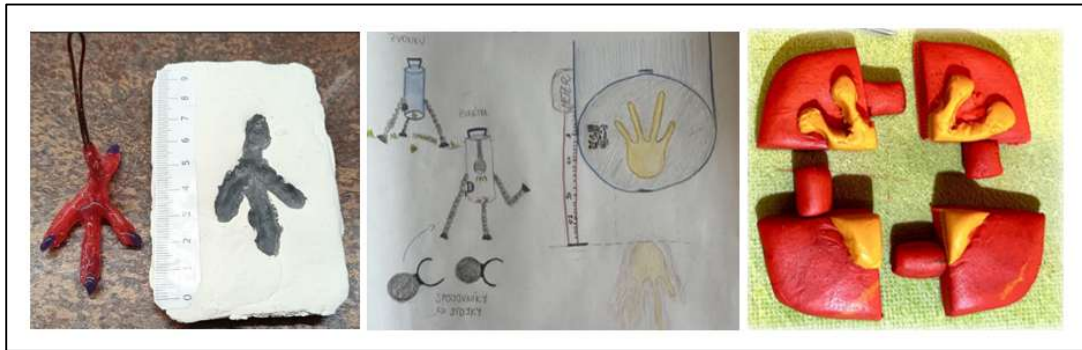

Figure 2. Prototypes of STEAM aids for determining species of birds, reptiles and amphibians

The selected prototype of a 3D aid for identifying animals by footprints, with which they could design a STEAM activity for primary science education, was visualized in the Tinkercad program. We present examples of 3D aids for identifying mammals, birds, reptiles and amphibians with an explanation of the use of the aid in primary science STEAM education.

Design and modelling of a 3D aid for determining mammals – plantigrades – the european hedgehog (Figure 3)

S (science) - place a short text on the aid about the hedgehog, its behaviour and importance in the ecosystem

T (technology) - stick a QR code with the sound of a hedgehog, stick a QR code with instructions on how to assemble the spines

E (engineering) - assemble the spines like a puzzle

A (art) - fill the track with different coloured plasticine or other modelling materials (make different coloured tracks)

M (mathematics) - record a meter on the aid, students can measure the track, compare the size, distance between the tracks, count the spines

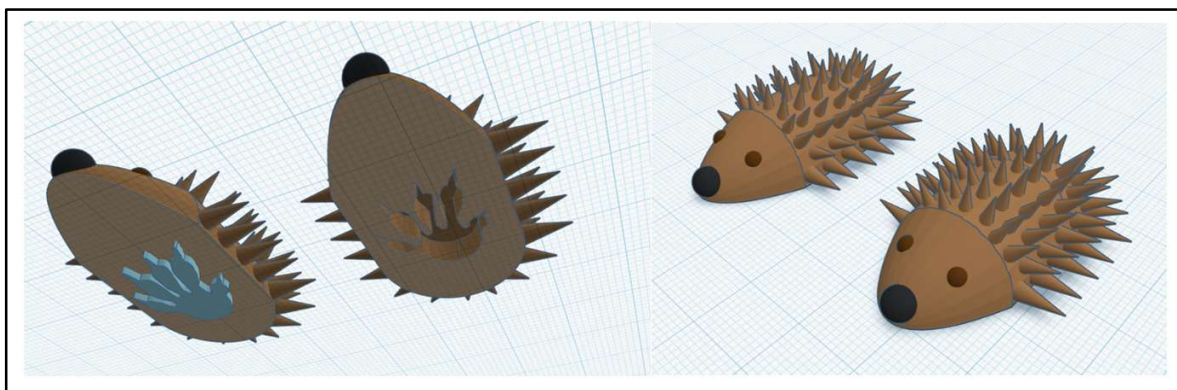



Co-funded by  
the European Union



Project: Accelerating STEAM-related  
Knowledge and Skills via 3D Modelling and 3D  
Printing  
Reg. no. 2023-1-CZ01-KA220-HED-000160664

Figure 3. 3D modelling of a STEAM aid for identifying mammals – plantigrades (european hedgehog) in the Tinkercad program

Design and modelling of a 3D aid for determining mammals - digitigrades - domestic cats (Figure 4)

S (science) - recognizing an animal's footprint and the typical sound that this animal makes, describing the animal and its characteristics

T (technology) - scanning a QR code with audio feedback representing the typical sound that a cat makes, using various materials (dough, plasticine, plaster) to make a footprint using the aid

E (engineering) - folding a puzzle - correct rotation when inserting the positive into the negative of the footprint and inserting it into a circular cutter (in the case of a memory game, also correct pairing), taking an animal's footprint

A (art) - multisensory perception - visual, tactile, auditory, printing 2D prints on paper, textile, 3D prints on various surfaces, e.g. soil, clay, wet sand, kinetic sand, plasticine

M (mathematics) – comparison with real prints – dealing with the concepts of bigger, smaller, identical, difference, putting together a puzzle, prints - dealing with the concepts of positive, negative, axial symmetry, cookie cutter – cutout in the shape of a cuboid, 2D print in the shape of a square

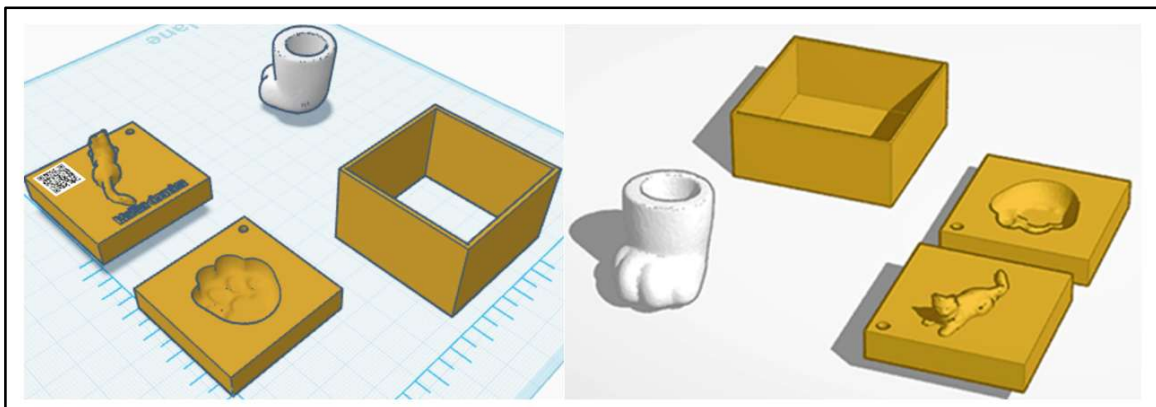

Figure 4. 3D modelling of a STEAM aid for identifying mammals – digitigrades (domestic cat) in the Tinkercad program

Design and modelling of a 3D aid for determining mammals - ungulates - roe deer (Figure 5)

S (science) - we investigate where prints can be made and thanks to this we know where to look for real tracks, comparison with real tracks



Co-funded by  
the European Union



Project: Accelerating STEAM-related  
Knowledge and Skills via 3D Modelling and 3D  
Printing  
Reg. no. 2023-1-CZ01-KA220-HED-000160664

T (technology) - design of a roe deer migration route via google maps, considering natural elements such as meadows, forests, fields, and rivers, using the aid to measure the length of the created route

E (engineering) + A (art) - drawing of a roe deer track according to the template in the aid, based on the sketch, modelling deer tracks from plasticine, imprinting the aid on the drawing in different colour combinations and in different directions, drawing the forest and meadow environment where the deer move on the drawing

M (mathematics) - using the track in the aid, various objects can be measured, for example, how many "deer tracks" a bench measures, blackboard, rug or bench in the yard

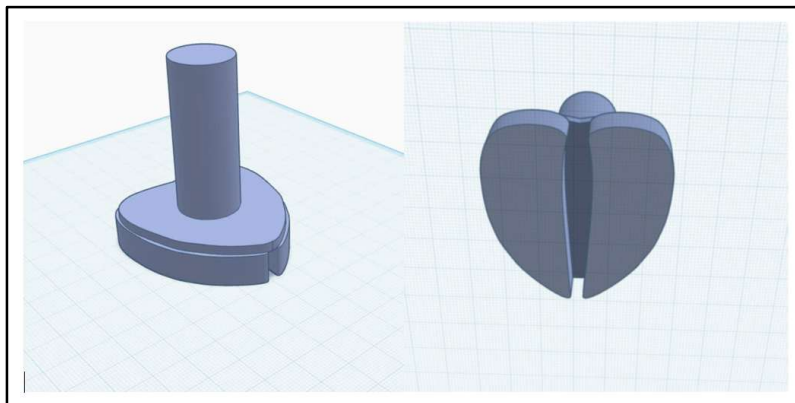

Figure 5. 3D modelling of a STEAM aid for identifying mammals – ungulates (roe deer) in the Tinkercad program

#### Design and modelling of a 3D aid for identifying birds - a domestic pigeon (Figure 6)

S (science) - examine the shape and size of a pigeon's footprint, compare the footprint of a pigeon with the footprints of other birds

T (technology) - scan the 3D model and try to transfer it to a digital environment (e.g. 3D scanner or photogrammetry), use applications for identifying bird footprints using mobile phones and augmented reality

E (engineering) - create your own 3D model of the foot and the imprint of a pigeon's footprint from plasticine or other suitable materials, assemble two components - create a puzzle where both parts can be used to identify the footprint

A (art) - create coloured prints of the model on paper and create patterns from them, create an art project on the topic of "Footprints in Nature", draw the second leg of a pigeon

M (mathematics) - measure the size of the footprint using a centimetre scale directly in the field, compare the size ratio of e.g. human footprints and pigeon footprints, the ruler on the aid can also be used to convert unit's cm → mm



Co-funded by  
the European Union



Project: Accelerating STEAM-related  
Knowledge and Skills via 3D Modelling and 3D  
Printing  
Reg. no. 2023-1-CZ01-KA220-HED-000160664

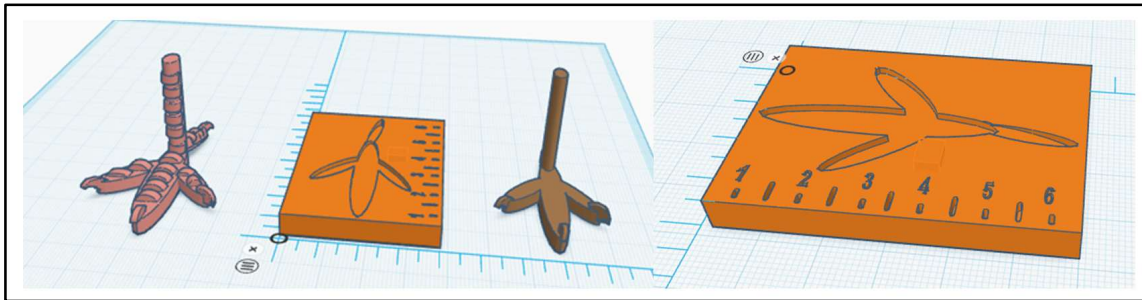

Figure 6. 3D modelling of a STEAM aid for identifying birds (domestic pigeon) in Tinkercad

Design and modelling of a 3D aid for identifying reptiles – wall lizards (Figure 7)

S (science) – observe and identify tracks of various reptile species directly in nature

T (technology) – QR code on track models (info about the animal)

E (engineering) – puzzle (attach flashlight, legs, meter...)

A (art) – tracing tracks according to shadows

M (mathematics) – measuring the distance from the aid to the track on the ground

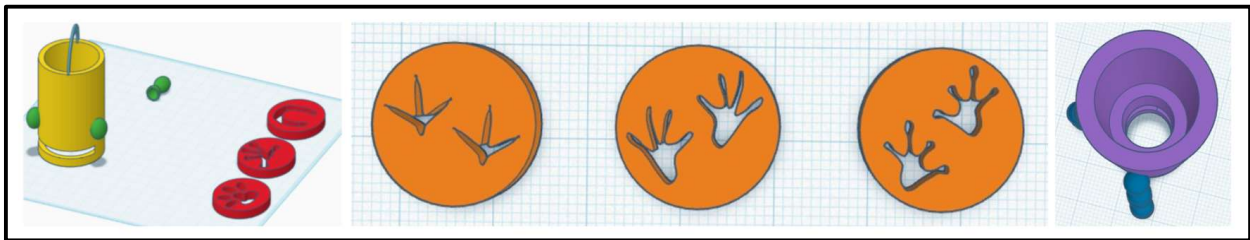

Figure 7. 3D modelling of a STEAM aid for identifying reptiles (wall lizards) in Tinkercad

Design and modelling of a 3D aid for identifying amphibians – the common toad (Figure 8)

S (science) – investigate the difference between jumping and walking toads, analyse their adaptation to the environment, and compare their tracks with those of other animals

T (technology) – use digital technology, such as mobile apps or shape analysis programs, to identify and compare different toad tracks

E (engineering) – correctly assemble the puzzle of the track and create toad prints in different materials, such as clay, sand, or plaster

A (art) – visualize the toad tracks yourself through drawings or models, or design of an artistic representation of different species of toads and their tracks in nature, while inspiration can be provided by shapes and patterns found in the real environment



Co-funded by  
the European Union



Project: Accelerating STEAM-related  
Knowledge and Skills via 3D Modelling and 3D  
Printing

Reg. no. 2023-1-CZ01-KA220-HED-000160664

M (mathematics) – by measuring and comparing tracks, students will master basic mathematical concepts such as scale, dimensions and proportions, while assembling the aid they will work with concepts – cube, cuboid, cylinder

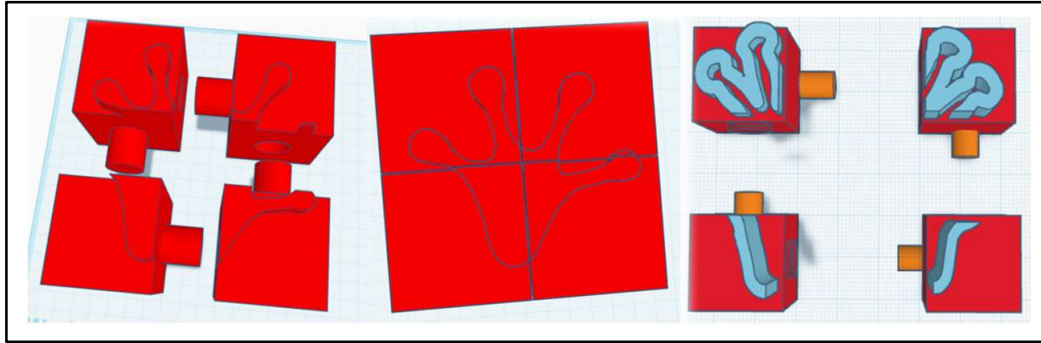

Figure 8. 3D modelling of a STEAM aid for identifying amphibians (warty toads) in Tinkercad

In terms of time, after the presentation of the projects, the students chose one design among themselves, which they printed using a 3D printer. Figure 9 shows the result of the 3D model of the domestic cat identification aid after printing with a 3D printer.



Figure 9. 3D model of an aid for identifying a domestic cat using its footprint, printed on a 3D printer

## Assessment – Overview

### Reflection / Evaluation – Feedback

After evaluating the projects, we found that all groups of students used different criteria when choosing a typical representative of a given group of animals, but they agreed that it must be an animal that younger school-age children can observe in their surroundings and thus see its typical footprint in a suitable background. The starting point for choosing an animal was therefore mainly the content and performance standards of the current SVP (2015, or 2023). Despite the fact that during the creation of the project, the students mainly solved technical tasks, because the project was technically demanding for them, all the proposed projects contained a correct design of the animal's footprint, even though not all students were able to transfer the technical details to the virtual environment of the Tinkercad program. However, each of the proposed aid projects was suitable for determining the animal in nature. The students were



Co-funded by  
the European Union



Project: Accelerating STEAM-related  
Knowledge and Skills via 3D Modelling and 3D  
Printing  
Reg. no. 2023-1-CZ01-KA220-HED-000160664

interested in this activity; they used various materials when creating prototypes and were really creative in their designs. In conclusion, we can conclude that even though the activity was technically challenging for students, it helped them understand the issue of recognizing animals by typical tracks, as well as introduce them to the teaching method within STEAM education.

### Assessment of 3D Modelling and 3D Printing (Detailed)

1) Does the student understand / know ...? – Method: [mind map]: The students considered the work in the Tinkercad program to be the most interesting part of the project, because it was a new method for them and they learned something new while creating the aid and working in the program. On the other hand, the students considered the work in the Tinkercad program to be the most challenging part of the project, because they had no experience with 3D modelling in the program. The students had difficulty designing more complex tracks, such as a frog's track, using geometric shapes in the program, so they used the drawing function instead, and it was more difficult for them to draw using the program than on paper. Some students said that they found it more difficult to design a aid that they had not designed themselves, but which they had agreed would meet the principles of STEAM education more closely or they were creating a new prototype. The work in the Tinkercad program took the most time to design and was technically challenging for them. Before the Science Practical class, less than 23% of the students knew the Tinkercad program. For this reason, we set aside one hour to familiarize ourselves with the method (with work in the Tinkercad and PrusaSlicer programs, as well as with the importance of STEAM science education). When planning similar activities, it is therefore important to familiarize students with the new technical method in advance so that individual disciplines are represented approximately equally within STEAM education. In our case, some students solved more technical tasks in the project than scientific ones and even used other technologies in the design itself (Google, YouTube, AI, Pinterest, printables, 3D printing, etc.).

2) Has the student created ...? – Method: [product evaluation]: After mutual consultation of the students, each group managed to come up with a final 3D aid that would be usable in its own way within primary science STEAM education. The biggest problem they had was implementing the element E – engineering within STEAM education. For example, with the aid for identifying the dark-skinned hedgehog, the students only indicated the possibility of inserting spines to assemble a complete model of the hedgehog later in the presentation. However, this element did not appear in the final design in the Tinkercad program. Alternatively, they chose a student activity to model a track using the created aid, which served as an example model. This element was most often discussed and consulted with the teacher by the students. Each student managed to design their final model in the program to varying degrees of quality, but not all models could be completely printed in 3D printing. For example, with the aid for identifying the wall lizard, some parts could not be printed, as the aid was designed as one whole. The second most common problem was designing two parts that were supposed to be axially symmetrical and therefore fit together like a puzzle. We introduced the students to the PrusaSlicer program, but only at the end of the project did the students have the opportunity to print one of the designed 3D aids. The Original Prusa i3 MK3S 3D printer model works slowly, so printing the aid took more than 4 hours (often a model reduced by 30-50% than the originally designed one). For 3D modelling and 3D printing, we therefore suggest devoting more time to the technical preparation of students so that during the Science Practicum class, students do not have to focus



Co-funded by  
the European Union



Project: Accelerating STEAM-related  
Knowledge and Skills via 3D Modelling and 3D  
Printing  
Reg. no. 2023-1-CZ01-KA220-HED-000160664

on solving more technical tasks than scientific ones. We assume that if students had more experience with 3D printing, similar errors in aid designs would be eliminated.

3) Can the student present ...? – Method: [presentation, peer review]: As part of the presentation of their proposals, each student in the group presented their design of a prototype aid, while being able to determine why their design could be suitable for STEAM education. During the presentation, they corrected some parts after watching another group of students present their designs and discussing them directly in class and were able to evaluate why their original design of a 3D aid was not suitable. If the design of a 3D aid within the group was the winner, which the students agreed best met all the conditions of STEAM education, the student who originally came up with the design often took the lead at the end of the presentation. Therefore, it seemed appropriate to divide some tasks that all students had to complete, not just the group of students, and the teacher's auxiliary questions to individual presenters. This was confirmed when presenting projects, where each student had a chance to express his or her opinion on the design of the aid, whether his or her original or newly created one.

4) Does the student implement / improve ...? – Method: [prototype revision]: When presenting their proposals, students most often corrected the element E - engineering and the element T - technology. In the group that designed a aid for identifying a dark hedgehog using a footprint, although they promptly modified their proposal to a jigsaw model, by making the individual cones like spikes that could be stuck into the hedgehog and thus create a complete hedgehog model, they did not incorporate this condition in the Tinkercad program. The use of the aid to develop students' digital literacy within STEAM education was most often eliminated in favour of the use of QR codes. In one case, students used the Google Maps application, with which they would determine the distance that the animal travelled using the footprint of the given aid (the so-called "deer footprint"), and in one case, they incorporated mobile applications that could identify the footprint (whether on the aid or actually created on a different substrate). Only some groups adapted the artistic element to STEAM education, e.g. creating the art project "Footprints in Nature" using the aid. Other groups composed this element only in the sense of creating an imprint in various materials (sand, clay, plasticine, paints, etc.) without an obvious connection to a natural science theme.

5) Teamwork ...? – Method: [observation, self-assessment]: Since we used the project method and group work within the project in the Science Practicum class, all students had to participate in the project. Despite the fact that most students considered the activity to be topical and interesting, despite its technical demands for elaboration and high level of creativity, some students stated that they had problems cooperating in the group, since the group members were selected by the teacher (randomly according to the alphabet of the last name). They would have preferred if they could choose their classmates for the group themselves. Natural leaders were more present in the group, e.g. if one student in the group invented a suitable aid right at the beginning, took the lead at the end of the project presentation, or he himself consulted with the teacher about some elements of STEAM education. In other groups, the rate of co-evaluation of the project was higher, since the teacher observed mutual discussion of project tasks outside of class. Despite the aforementioned initial problems, all students managed to create a model of the aid in the group (either in a drawing and modelling design or a model in the Tinkercad program) and present their designs, either within the group or at the end of the lesson. The teacher did not know the students who completed the Science Practical in advance, but we suggest either choosing a random



Co-funded by  
the European Union



Project: Accelerating STEAM-related  
Knowledge and Skills via 3D Modelling and 3D  
Printing  
Reg. no. 2023-1-CZ01-KA220-HED-000160664

selection of students, or if the teacher knows the students, assigning only one natural leader to each group so that problems do not arise in solving the project in the group. It is also appropriate for individual group members to set tasks in advance that all students within the group must complete so that students work on the project with each other.

### Additional Information (Optional)

Notes: The aids can be used in the field as well as in a classroom environment, or for the blind.

Teaching Resources / Support Materials: various types of material for making footprints – plasticine, kinetic sand, plaster – 3D footprints; paint, ink, paper – 2D footprints; mobile phone with applications for recognizing footprints – e.g. Google Lens, scanning footprints – Magiscan, images of footprints and information about the animal – QR generator, flashlight to illuminate footprints

Evaluation Resources / Materials: opinion questionnaire on STEAM activity

Other Resources / Materials: photography of prototypes, digital STL files

### References

Dobišová Adame, R. & Kováčiková, O., 2015. *Prvouka pre 1. ročník základnej školy. Metodické komentáre*. AITEC, Bratislava, 96 s.

Gibson, Ch., 2005. *Príroda do vrecka. Zvieratá Európy*. Slovart, Bratislava, 224 s.

Guenther, C., Hayes, M., Davis, A., Stern, M. 2021. Building Confidence: Engaging Students Through 3D Printing in Biology Courses. *Bioscene: Journal of College Biology Teaching*, 47(1): 40-58

Hansen, A. K., Langdon, T. R., Mendrin, L. W., Peters, K., Ramos J & Lent, D. D. 2020. Exploring the Potential of 3D-printing in Biological Education: A Review of the Literature. *Integrative and Comparative Biology*, 60(4): 896–905. doi:10.1093/icb/icaa100

Hecker, F., 2019. *Spoznaj zvieratá podľa stôp*. Ikar, Bratislava, 111 s.

Jho H., Hong O. & Song J., 2016. An analysis of STEM/STEAM teacher education in Korea with a case study of two schools from a community of practice perspective. *Eurasia Journal of Mathematics, Science & Technology Education*, 2016, 12(7): 1843-1862 doi: 10.12973/eurasia.2016.1538a

Leutscher, A., 1996. *Stopy a značky zvierat*. Mladé letá, Bratislava, 64 s.

Lisak, F., 2004. *Stopy*. Slovart, Bratislava, 32 s.

Perignat, E., & Katz-Buonincontro, J., 2019. STEAM in practice and research: An integrative literature review. *Thinking Skills and Creativity*, 31, 31–43. <https://doi.org/10.1016/j.tsc.2018.10.002>

Richarz, K., 2009. *Atlas stop zvířat. Jak je poznávat a určovat*. ACADEMIA, Praha, 189 s.

Sieińska, K. & Ordza, T., 2022. Best practice guide of STEAM methodology in eTwinning projects for future teachers. European Commission, Online Available (09-01-2025): <https://school-education.ec.europa.eu/en/discover/research/ecr2022-steam-methodology-etwinning?prefLang=sk>



Co-funded by  
the European Union



Project: Accelerating STEAM-related  
Knowledge and Skills via 3D Modelling and 3D  
Printing  
Reg. no. 2023-1-CZ01-KA220-HED-000160664

Svojtka & Co., 2014. *Stopy živočíchov*. Svojtka&Co., Bratislava, 256 s.

Štátny vzdelávací program pre základné vzdelávanie. (2025, 3. februára).

[https://www.minedu.sk/data/files/11808\\_statny-vzdelavaci-program-pre-zakladne-vzdelavanie-cely.pdf](https://www.minedu.sk/data/files/11808_statny-vzdelavaci-program-pre-zakladne-vzdelavanie-cely.pdf)

Townsend, J., 2018. *Stopy zvierat z celého sveta v skutočnej veľkosti*. Slovart, Bratislava, 50 s.